

WOOD DESTROYING PESTS AND ORGANISMS INSPECTION REPORT

Building #, Street, City, State, Zip 3660 Larry Court, San Jose, CA 95121	Date of Inspection 3/9/2021	# Pages 11
---	---------------------------------------	----------------------

ANTIQUUE TERMITE, INC. 1913 Stone Avenue, San Jose, CA 95125 Phone: (408) 995-6300 Email: info@antiquetermite.com	RECEIVED & READ	PR 1187 
Report #: 63090	_____ SIGNATURE DATE	
	_____ SIGNATURE DATE	

Ordered By: Dave Clark Keller Williams Realty 2110 S. Bascom Avenue, Ste 101 Campbell, CA 95008	Property Owner/Party of Interest: Ramona Esparza	Report Sent To:
---	---	-----------------

COMPLETE REPORT: LIMITED REPORT: SUPPLEMENTAL REPORT: REINSPECTION REPORT:

General Description: ONE STORY SINGLE FAMILY DWELLING WITH WOOD FRAME AND WOOD SIDING/STUCCO EXTERIOR	Inspection Tag Posted: GARAGE
	Other Tag(s) Posted:

An inspection has been made to the structure(s) shown on the diagram in accordance with the Structural Pest Control Act. Detached porches, detached steps, detached decks and any other structures not on the diagram were not inspected.

Subterranean Termites: Drywood Termites: Fungus/Dryrot: Other Findings: Further Inspection:

If any of above boxes are checked it indicates that there were visible problems in accessible areas. Read the report for details on checked items.

DIAGRAM NOT TO SCALE

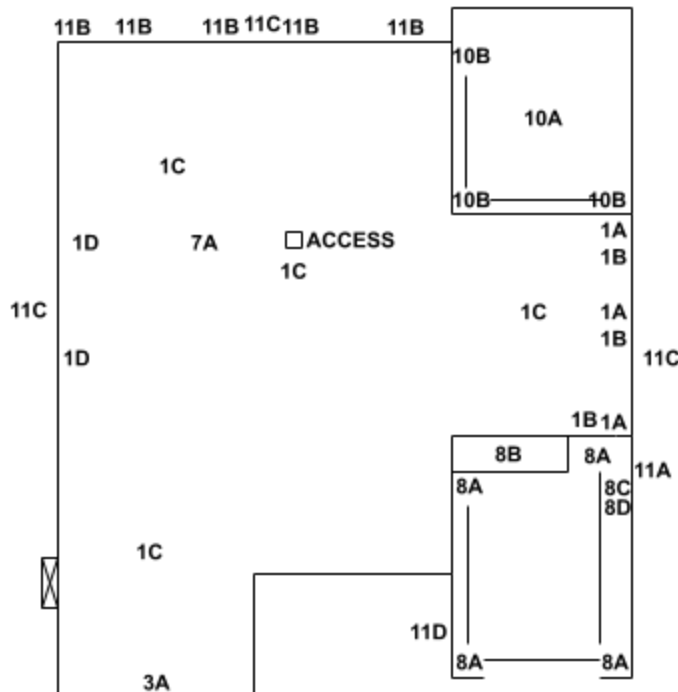

Inspected by: Aaron J. Miranda

State License #: FR32796

Signature:

Aaron Miranda

You are entitled to obtain copies of all reports and completion notices on this property reported to the Structural Pest Control Board during the preceding two years. To obtain copies contact: Structural Pest Control Board, 2005 Evergreen Street, Suite 1500, Sacramento, CA 95815.

NOTE: Questions or problems concerning the above report should be directed to the manager of the company. Unresolved questions or problems with services performed may be directed to the Structural Pest Control Board at (916) 561-8708, (800) 737-8188 or www.pestboard.ca.gov.

ANTIQUE TERMITE, INC.

Address: 1913 Stone Avenue, San Jose, CA 95125

Phone: (408) 995-6300

Email: info@antiquetermite.com

Building #, Street, City, State, Zip 3660 Larry Court, San Jose, CA 95121	Date of Inspection 3/9/2021	Report # 63090
---	---------------------------------------	--------------------------

AREAS NOT INSPECTED: The interior of hollow walls, areas beneath and behind built in cabinets were not inspected since inspection of these areas are considered impractical. We did not water test and do not certify against leakage of any appliances, plumbing over finished ceilings, roof coverings, or decks. Such actions were not performed as they are considered impractical without specific written authorization. Floors which are carpeted makes inspection of the flooring in these areas impractical. Soffitted (enclosed framing) areas of the structure makes inspection of interior framing inaccessible for inspection. We make no guarantee against infestations, leaks or adverse conditions which may exist in such areas not inspected. Attached and/or detached fences were not inspected unless otherwise stated in the body of this report. Further inspection is recommended. Further inspection of any inaccessible area and/or area not inspected would be performed upon request at an additional charge (with written authorization). This property was not inspected for the presence or absence of health related molds or fungi. By California Law we are neither qualified, authorized, nor licensed to inspect for health related molds or fungi. If you desire information about the presence or absence of health related molds, you should contact an industrial hygienist.

No furniture or appliances were moved or removed, limiting this inspection to the visible and accessible areas of the above structure shown on the diagram. No statements can be made regarding conditions in closed walls, floors beneath coverings, areas below or behind appliances and built-in cabinet work, stall showers over finished ceilings, such structural segments as porte cocheres, enclosed bay windows, buttresses and similar areas to which there is no access without defacing or tearing out lumber, masonry or finished work. The exterior surface of the roof was not inspected. If interested parties want water tightness of the roof determined, they should contact a roofing contractor who is licensed by the Contractors State License Board. Antique Termite assumes no responsibility for leaks not evident during the time of this inspection. Our inspectors are not equipped with extension ladders, therefore all buildings will be inspected from the ground level only. All wood members above 10 feet from the ground level would be visually inspected only (no probing, etc). Further inspection of these inaccessible area(s) not inspected is recommended and will be performed upon request and at an additional fee.

REINSPECTIONS: If requested by the person ordering this report, a reinspection of the structure will be performed. This company will reinspect repairs done by others within four (4) months of the date of the original inspection. A charge, if any, can be no greater than the original inspection fee for each reinspection. The reinspection must be done within ten (10) working days of request. The reinspection is a visual inspection and if inspection of concealed areas is desired, inspection of work in progress will be necessary. Any guarantees must be received from parties performing repairs. Antique Termite Inc. does not guarantee work performed by others.

All repairs completed by others must be reinspected by Antique Termite before certification will be issued. The reinspection will only CERTIFY the absence of infestation of infection in the visible and accessible areas. Antique Termite does not guarantee work completed by others, nor does this firm make any statements concerning workmanship of those repairs. Workmanship is only determinable by those paying for or receiving those services. A reinspection of specific items on the report or of any other condition pertaining to this structure can be done at an additional cost of \$150.00 per trip. Any reinspection must be performed within four (4) months of the original inspection report. A REINSPECTION FEE OF \$150.00 IS PAYABLE AT THE TIME OF EACH REINSPECTION.

GUARANTEES: Guarantees on work (labor) performed by Antique Termite Inc. are for one (1) year from the date of completion. Guarantees for local chemical treatments are limited to wood members treated only. Fumigations are guaranteed for three years from the date of completion. Plumbing repairs (parts provided by this firm), linoleum (vinyl materials), toilet resets or any other measures for the control of moisture (caulkings and grouts etc.) are guaranteed for thirty (30) days. Antique Termite, Inc. assumes no responsibility for water damage if the shower enclosure is not installed immediately. The guarantee on showers and tub units is void if the area is used before 24 hours. If the shower fixtures do not fit the owner must contact other tradesman to have new fixtures installed. If necessary for floor installation, vanities are to be removed and replaced by others. Kitchens and laundry areas also must have appliances removed before installation. An additional fee of \$75.00 per appliance and or furniture will be charged for Antique Termite to remove and/or reinstall. We do not do painting, texturing, staining or wallpapering.

Notice: Reports on this structure prepared by various registered companies should list the same findings (i.e. termite infestations, termite damage, fungus damage, etc.) However, recommendation to correct these findings may vary from company to company. You have a right to seek a second opinion from another company.

WHILE PERFORMING TREATMENTS OR ANY CONSTRUCTION REPAIRS, ANTIQUE TERMITE INC. WILL NOT BE RESPONSIBLE OR LIABLE FOR ANY DAMAGE TO ELECTRICAL OR PLUMBING WHICH MAY BE CONCEALED IN WALLS OR BELOW SLABS. BUILDING PERMITS REGARDING REPAIRS WHICH A BUILDING PERMIT IS REQUIRED, IF IT IS FOUND THAT LOCAL BUILDING CODES REQUIRE ADDITIONAL REPAIRS TO BE PERFORMED, THESE ADDITIONAL REPAIRS WOULD BE AT THE OWNER'S EXPENSE AND SAME WOULD BE OUTLINED A SUPPLEMENTAL REPORT.

ANTIQUE TERMITE, INC.

Address: 1913 Stone Avenue, San Jose, CA 95125

Phone: (408) 995-6300

Email: info@antiquetermite.com

Building #, Street, City, State, Zip 3660 Larry Court, San Jose, CA 95121	Date of Inspection 3/9/2021	Report # 63090
---	---------------------------------------	--------------------------

TILE OR LINOLEUM SELECTIONS: Bids which are given in report for replacement of ceramic tile or linoleum are based on using standard grade material. Ceramic tile bids are based on standard-square 4 tiles at a cost of \$2.78 per square foot for shower walls or tub shower walls. Ceramic floor tile bids are based on 8x8 tiles at \$2.75 per square foot. Tile selections can be made at Dal Tile 2549 Zanker Road San Jose CA 95131 408-435-1566. Linoleum bids are based on using standard grade linoleum at \$.99 per square foot. Linoleum selections can be made at S&G Carpet 4952 Almaden Expressway, San Jose, CA 95118 (408) 414-1188 Tile and/or linoleum selections must be made at least 5 days prior to scheduled repairs. Any upgrades, must be paid by client at the time of selection. If NO selection is made prior to repairs, standard/neutral color tile or sheet vinyl will be installed.

MOLD POLICY STATEMENT: Molds, sometimes called mildew, are not wood destroying organisms. Branch 3 licensees do not have a duty under the Structural Pest Control Act and related regulations to classify molds as harmful to human health or not harmful to human health. This does not modify the Structural Pest Control Act or related regulations.

SECONDARY RECOMMENDATION (SUB STANDARD): Anytime a secondary recommendation (local treatment) is recommended, we must state who requested this secondary recommendation. Secondary recommendations are considered substandard recommendations and guarantees are limited to treated areas only as stated in report.

Addendum to Contract: Due to recent changes in the law, we are required to give you the following notice. If our inspection report contains a recommendation for lethal gas fumigation, this company subcontracts lethal gas fumigation to: Cost Less Fumigation Inc. (408) 918-9100 or NorCal Fumigation (408) 320-2158.

Notice: The charge for service that this company subcontracts to another registered company may include the company's charges for arranging and administering such services that are in addition to the direct costs associated with paying the subcontractor. You may accept Antique Termite Inc.'s bid or you may contract directly with another registered company. Antique Termite Inc. will not be responsible for any act or omission in the performance of work that you directly contract with another to perform. By signing the attached contract, you authorize Antique Termite Inc. to subcontract this fumigation to a registered fumigation company.

WORK DONE BY OTHERS: Antique Termite, Inc. does not guarantee work performed by others. Such guarantees should be obtained from those performing the repairs. Antique Termite, Inc. only certifies the absence of infestation or infection in the visible and accessible areas. If it is found that others have concealed or hidden infestations or infections during the course of their repairs, it will be the responsibility of interested parties to pursue the responsible party. Antique Termite, Inc. does not inspect for or comment on workman-like manner on repairs done by others. Interested parties must satisfy themselves with the proper permits and licenses and to the quality or appearance of work which is not completed by our company.

INACCESSIBLE AREAS: During the course of repairs as outlined in this report, **IF damage and/or infestation is found to extend into previously inaccessible areas, a supplemental report will be issued outlining findings and costs for any additional repairs or treatments. Antique Termite Inc. does not do any texturing, painting or wallpapering.**

THIS IS A SEPARATED REPORT WHICH IS DEFINED AS SECTION I, SECTION II AND UNKNOWN FURTHER INSPECTION CONDITIONS EVIDENT ON THE DATE OF INSPECTION.

- SECTION I: Contain items where there is evidence of active infestations, infections, or conditions which have resulted in or from infestations or infection.
- SECTION II: Are conditions deemed likely to lead to infestation or infection, but where there is no visible evidence of such found.
- UNKNOWN FURTHER INSPECTION (F/I): Recommendations to inspect areas which during the original inspection did not allow the inspector access to complete the inspection and cannot be defined as Section I or Section II.

ANTIQUE TERMITE, INC.

Address: 1913 Stone Avenue, San Jose, CA 95125

Phone: (408) 995-6300

Email: info@antiquetermite.com

Building #, Street, City, State, Zip 3660 Larry Court, San Jose, CA 95121	Date of Inspection 3/9/2021	Report # 63090
---	---------------------------------------	--------------------------

1 - Subarea

ITEM 1A FINDING: Evidence of infestation by drywood termites was noted at the subarea wood members in the area indicated on the diagram. These infestations appear to extend into inaccessible areas.

**SECTION I
FUMIGATION****\$2009.00**

RECOMMENDATION: Seal up and fumigate the entire structure with a lethal gas (VIKANE/SULFURYL FLUORIDE AND CHLOROPICRIN) for the control of drywood termites in all areas of the structure. Remove the seals for reoccupancy.

NOTE: Antique Termite is not liable for any damage which may occur to roof or plant life during fumigation. Fumigation cannot begin during inclement weather. In the case of rain or strong winds the job may be postponed to a later date. Additional information will be shown on the occupants' fumigation notice which must be signed and returned to the fumigation department before the fumigation date. Structure must be vacated for two nights (one night to fumigate, one night to allow for proper ventilation). All preparation work to get structure ready for fumigation is owner/occupants' responsibility. Should owner desire a fumigation prep company to do the necessary prep-work, they should contact fumigation department--there is a cost for this service, which will be in addition to price for fumigation. FUMIGATION WARRANTY IS FOR THREE YEARS FROM DATE OF COMPLETION.

NOTE: Our bid does not include any prep work. All instructions must be thoroughly read and performed. Failure to complete fumigation prep or failure to return signed papers prior to fumigation date will result in cancellation and/or rescheduling. Specific preparation instructions will be issued once fumigation is ordered.

NOTE: If fumigation is prepaid in full prior to fumigation date, discounted cost for fumigation would be \$1859.00.

ITEM 1B FINDING: Evidence of infestation by drywood termites was noted in item 1A (fecal pellets).

**SECTION I
MASK PELLETS****\$225.00**

RECOMMENDATION: In compliance with the Structural Pest Control Board, remove or mask over all accessible drywood termite evidence (pellets) upon completion of treatments.

ITEM 1C FINDING: Earth contact was noted at the cellulose debris (wood scraps, cardboard, etc.) in the subarea.

**SECTION II
PREVENTATIVE****\$250.00**

RECOMMENDATION: Remove all cellulose debris of a rakeable size or larger.

ITEM 1D NOTE: The master bathroom stall shower and hall bathroom tub shower were water tested at the time of this inspection. No leaks were detected at this time.

NOTE**3 - Foundations**

ITEM 3A FINDING: Minor vertical cracks were noted at the foundation. These cracks could lead to moisture intrusion and/or infestation by subterranean termites.

**SECTION II
PREVENTATIVE****OTHERS**

RECOMMENDATION: Engage the services of the appropriate, licensed tradesperson to check this condition and make any necessary recommendations and repairs.

ANTIQUE TERMITE, INC.

Address: 1913 Stone Avenue, San Jose, CA 95125

Phone: (408) 995-6300

Email: info@antiquetermite.com

Building #, Street, City, State, Zip 3660 Larry Court, San Jose, CA 95121	Date of Inspection 3/9/2021	Report # 63090
---	---------------------------------------	--------------------------

7 - Attics

- ITEM 7A** FINDING: Portions of the attic framing are inaccessible for inspection due to insulation. The attic was inspected from the access opening only. Interested parties should be aware that Antique Termite Inc. assumes no responsibility for any inaccessible areas.
- UNKNOWN F/I**
- BID ON REQ** RECOMMENDATION: If further inspection is desired, access to this area must be provided by others by installing cat walks or removing the insulation. Please call our office if you would like to schedule an appointment for further inspection.

8 - Garages

- ITEM 8A** FINDING: Portions of the garage framing are inaccessible for inspection due to storage and/or free standing cabinets. Interested parties should be aware that Antique Termite, Inc. assumes no responsibility for any inaccessible areas.
- UNKNOWN F/I**
- \$150.00** RECOMMENDATION: Further inspection is recommended. The owner/occupant is advised to move the storage and/or free standing cabinets. At that time and upon request, we would return, perform further inspection, and issue a supplemental report with any findings.
- ITEM 8B** FINDING: There is a portion of the substructure which is inaccessible for inspection. This area is inaccessible due to sleeper floor construction (framing over slab with no access).
- UNKNOWN F/I**
- BID ON REQ** RECOMMENDATION: Further inspection recommended. Open this area, perform further inspection and issue a supplemental report on any findings.
- ITEM 8C** FINDING: Evidence of drywood termites was noted at the garage wall as viewed through the vent.
- SECTION I FUMIGATION** RECOMMENDATION: See recommendation in item #1A above regarding fumigation of entire structure.
- INCL. W/ 1A**
- ITEM 8D** FINDING: Evidence of infestation by drywood termites was noted in item 8C (fecal pellets).
- SECTION I MASK PELLETS** RECOMMENDATION: In compliance with the Structural Pest Control Board, remove or mask over all accessible drywood termite evidence (pellets) upon completion of treatments.
- \$200.00**

10 - Interior

- ITEM 10A** NOTE: A portion of the dwelling is constructed over a concrete slab with finished walls on the interior and exterior which limits our inspection to the accessible areas. No representation can be made in regards to the absence or presence of infestations or infections in these inaccessible areas.
- NOTE**
- ITEM 10B** NOTE: The eave areas above the patio cover are inaccessible for inspection. Interested parties should be aware that Antique Termite, Inc. assumes no responsibility for any inaccessible areas.
- NOTE**

ANTIQUE TERMITE, INC.

Address: 1913 Stone Avenue, San Jose, CA 95125

Phone: (408) 995-6300

Email: info@antiquetermite.com

Building #, Street, City, State, Zip 3660 Larry Court, San Jose, CA 95121	Date of Inspection 3/9/2021	Report # 63090
---	---------------------------------------	--------------------------

11 - Exterior

ITEM 11A FINDING: Fungus damage was noted at the small garage door and jambs.

SECTION I RECOMMENDATION: Remove the damaged door and install a new comparable, pre hung door
WOOD REPAIR with jambs reusing existing hardware.

\$785.00 NOTE: We do not guarantee matching existing door. The replacement door will be a readily available door.

ITEM 11B FINDING: Screed boards about the structure.

SECTION II RECOMMENDATION: Cut back screed boards where they touch the structure and fill the voids
PREVENTATIVE with mortar.

OTHERS

ITEM 11C FINDING: The exterior stucco extends into the soil (base of foundation or slab not exposed).
SECTION II While this may have been a common building/construction practice at the time this structure
PREVENTATIVE was built, it can limit the ability of the inspector to detect subterranean termite activity behind the stucco. This type of construction may also inhibit the effectiveness of treatments for subterranean termites (if present) due to the fact that a chemical barrier may not be able to reach the foundation.

OTHERS

RECOMMENDATION: Engage the services of the appropriate, licensed tradesperson to cut off the base of the stucco (leaving an exposed portion of the foundation or slab), while still covering the mudsill.

ITEM 11D FINDING: Gutters are showing signs of minor leaks.

SECTION II RECOMMENDATION: Owner to contact other trades to seal/repair the gutters.
PREVENTATIVE

OTHERS**Post Notes**

Chemical Notes: CHEMICAL NOTE: Section 8538. (a): 'State law requires that you be given the following information: CAUTION--PESTICIDES ARE TOXIC CHEMICALS. Structural Pest Control Companies are registered and regulated by the Structural Pest Control Board, and apply pesticides which are registered and approved for use by the California Department of Pesticide Regulation and the United States Environmental Protection Agency. Registration is granted when the state finds that based on existing scientific evidence there are no appreciable risks if proper use conditions are followed or that the risks are outweighed by the benefits. The degree of risk depends upon the degree of exposure, so exposure should be minimized.'

'If within 24 hours following application you experience symptoms similar to common seasonal illness comparable to the flu, contact your physician or poison control center (800-876-4766) and your pest control operator immediately.' (This statement shall be modified to include any other symptoms of overexposure which are not typical of influenza.)'

FUMIGATION NOTE: 'If within 24 hours you experience symptoms of dizziness, headache, nausea, reduced awareness, slowed movement, garbled speech or difficulty in breathing, leave the structure immediately and seek medical attention by contacting your physician or Poison Control Center (800-876-4766) and notify your pest control company. The warning agent, chloropicrin, can cause symptoms of tearing, respiratory distress and vomiting. Entry into the space during fumigation can be fatal'

ANTIQUE TERMITE, INC.

Address: 1913 Stone Avenue, San Jose, CA 95125

Phone: (408) 995-6300

Email: info@antiquetermite.com

Building #, Street, City, State, Zip 3660 Larry Court, San Jose, CA 95121	Date of Inspection 3/9/2021	Report # 63090
---	---------------------------------------	--------------------------

Chemical Contact Information: For further information, contact any of the following:

Antique Termite Inc. (408) 995-6300, for general questions
 County Health Dept (408) 918-3400, for health questions
 County Agriculture Commissioner (408) 918-4600, for application questions

Structural Pest Control Board
 2005 Evergreen Street Ste #1500
 Sacramento, CA 95825
 (916) 561-8700, for regulatory information

Chemical Manufacturers & Active Ingredients: The following list of chemicals may be used by Antique Termite Inc. in the treatment of the above mentioned property:

Name: Cy-Kick (Manuf: Cy-Kick/Whitmire Micr-Gen, Active Ingredient: Cyfluthrin)
 Name: Premise Foam (Manuf: Bayer Corporation, Active Ingredient: Imidacloprid)
 Name: Tim-Bor (M: US Borax & Chemical Corp, AI: Disodium Octaborate Tetrahydrate)
 Name: Termidor-HE (Manuf: Termidor/BASF, Active Ingredient: Fipronil:Pyrazole)
 Name: Termidor Foam (Manuf: Termidor Foam/BASF, Active Ingredient: Fipronil:Pyrazole)
 Name: Termidor Dry (Manuf: Termidor Dry/BASF Corp, Active Ingredient: Fipronil:Pyrazole)
 Name: Vikane (Manuf: Dow AgroSciences, Active Ingredient: Sulfuryl Fluoride)

FUMIGATION NOTICE: Structural fumigants are colorless, odorless, and do not affect paints, finishes, or fabrics. Dishes and utensils can be used without washing. By Federal law and as indicated by the label, the following items must be removed before fumigation with any fumigant. Persons, plants, pets, baby mattresses enveloped with plastic covers. All food and medicines not sealed in glass or metal containers. This includes food in refrigerator and freezers. It is to the responsibility of the occupant to have these items removed.

Soil should be soaked with water at least 12 feet from the foundation outward. This can be done the evening before and may help to protect plants. Vines and shrubs connected to the structure must be freed by the owner with ample space provided to get fumigation tarps behind same. All antennae and roof ornaments must be removed by owner or occupant. All automatic timing devices (sprinklers, lights, etc.) must be disconnected during fumigation. Solar systems must be turned off and drained. Should the owner desire a fumigation prep company to perform the necessary prep-work, please contact our office and we can give you the name and phone number of a company which can perform the necessary prep work for a fee. It is the responsibility of the owner to take care of all necessary prep work. If prep work is not done when fumigation crew arrives, the job will be canceled for that day.

Our crews must fumigate several structures in various locations each day. Therefore, the time that any fumigation is scheduled for must be approximate only. Most fumigations are scheduled for sealing sometime during the first day and opened the next day after proper exposure to the fumigant. The time for ventilation varies and in most cases the building will not be certified for re-occupancy until late afternoon the day after it is opened. The structure must be vacated for approximately 72 hours. The tarps will be put up the date scheduled, removed the following date, aired out, and then declared safe to re-enter the date after the tarps have been removed. A sign will be posted on the front door as to when structure is safe to re-enter. We do not wish to inconvenience you by having you wait for the arrival of fumigation crew. When you decide on a date, make arrangements about the keys and leave with the assurance that your building will be properly fumigated.

ANTIQUE TERMITE, INC.

Address: 1913 Stone Avenue, San Jose, CA 95125

Phone: (408) 995-6300

Email: info@antiquetermite.com

Building #, Street, City, State, Zip 3660 Larry Court, San Jose, CA 95121	Date of Inspection 3/9/2021	Report # 63090
---	---------------------------------------	--------------------------

**FUMIGATION
NOTICE
(CONTINUED):**

The GAS service must be shut off prior to fumigation. The fumigation company will contact PG&E to schedule to have service turned off. It is the owner's responsibility to contact PG&E to come back out to the property to turn the gas service back on and relight pilot lights. Homeowner should contact PG&E at least 4 days in advance to schedule them to come back out. PG&E will not turn service back on unless they are shown the re-entry notice which the fumigation company has posted at the structure stating when it is safe to re-enter. Its mandatory that the owner/agent show this notice to PG&E or they will leave the property and reschedule to come back out to the structure once that notice is made available to them. Electricity will remain on.

The utmost care will be taken during fumigations to avoid any possible roof or plant damage. However, in the case of brittle wood shingles or tiles, there is always the possibility of some breakage. Where climbing plants and vines must be detached from the buildings or trellises removed, damage may be unavoidable. Plants that are too close to the structure to allow proper sandbagging of the tarps may be damaged. We can assume NO responsibility for damage resulting from these conditions.

This building will be fumigated with poisonous gases. All persons and animals MUST vacate the premises when the fumigation crew arrives. Under NO circumstances can anyone enter the structure until the fumigation company's notice is posted giving the time and date for safe re-entry. Fumigation cannot commence without a signed notice 'Occupants Fumigation Notice in fumigator's possession which will be sent out once fumigation date has been scheduled and will have any additional notes as to the prep work which must be done prior to the fumigation date by OCCUPANT. Should you have any questions regarding fumigation, please contact our office at (408) 995-6300 or the fumigation company.'

**FACT SHEET FOR
VIKANE
(SULFURYL
FLUORIDE)**

In the interest of Dow Elanco's commitment to product stewardship, this fact sheet is intended to provide basic information and how it is used. If you have additional questions about Vikane or the procedures described, call the Dow Elanco Customer Information Services at 1-800-352-6776.

**WHY BUILDINGS
ARE FUMIGATED**

Insects that feed or tunnel into the wood can seriously damage houses, apartments, and other dwellings or structures. Each year termites or other wood destroying insects damage approximately 2 million homes. Depending on the extent or location of the infestation, fumigation is the only total control method proven to eliminate certain infestations of wood destroying insects.

**HOW BUILDINGS
ARE FUMIGATED**

Because Vikane is a gas, prior to fumigation the structure is completely sealed. This serves to contain Vikane in the building so it can penetrate wood thoroughly and eliminate the pests. Depending on the construction of the building, the doors and windows may be sealed with tape and a plastic sheet, or the structure may be covered with a tarp. The building will remain sealed for 4 to 72 hours depending on the specifics of the job. Warning signs are posted around the building-notifying people to keep out. After the tarp is removed, a professional fumigator will aerate the structure by opening the doors and windows. Fans may also be used to clear out the building. Once the building has been thoroughly aerated, the fumigator is required to measure the level of any fumigant remaining in the living space to ensure it is below the established safe re-entry concentration. Your building should not be cleared for re-occupancy until it is safe to enter. The fumigator will post a notice on your building indicating the day and time for re-entry. Structures can be occupied only when the concentration is 5 parts per million or less (this represents a margin of safety - laboratory animals have been exposed to 100 parts per million for 2 weeks with no adverse effects). Because Vikane is a true gas and not a vapor, aeration is rapid. Recent studies demonstrated that in most structures levels are less than 1 part per million within 6 hours of clearing and have no detectable levels of Vikane with 24 hours after the start of Aeration. Sulfuryl Fluoride is a colorless, odorless gas, so a warning agent is added to the building, which causes watery eyes and a scratchy throat. If you experience these symptoms in a structure that has been recently fumigated, you should leave immediately and call the pest control company to have your building re-tested.

ANTIQUE TERMITE, INC.

Address: 1913 Stone Avenue, San Jose, CA 95125

Phone: (408) 995-6300

Email: info@antiquetermite.com

Building #, Street, City, State, Zip 3660 Larry Court, San Jose, CA 95121	Date of Inspection 3/9/2021	Report # 63090
---	---------------------------------------	--------------------------

SULFURYL FLUORIDE &

Sulfuryl Fluoride is a gas and can potentially enter your body through inhalation. Because it is a gas, it does not stay on dry surfaces, therefore, there is no exposure from touching treated surfaces.

POTENTIAL HEALTH RISK FROM OVEREXPOSURE

Nervous system and respiratory irritation: Over exposure to high levels of Sulfuryl Fluoride can result in nose and throat irritation and nausea. At high concentrations (such as those used during the fumigation), can cause excess fluid in the lungs, sleepiness, pneumonia, and convulsions. These symptoms would be expected to appear within 8 hours after such exposure. In the unlikely event that you experience these symptoms in a building that has been recently fumigated, you should leave immediately. Consult your physician and call the pest control company to have your building re-tested.

Additional studies: Sulfuryl Fluoride has not been shown to cause birth defects in pregnant animals, exposed under experimental conditions. In addition, current studies have demonstrated there are no mutagenic or genotoxic effects caused by exposure to Sulfuryl Fluoride.

SAFETY PRECAUTIONS AND HOMEOWNER PREPARATION

- * Discuss the treatment program in advance with your pest control company so you fully understand what will be done and what you need to do.
- * Carefully follow the instructions you are given about what items you are to remove from your building.
- * If you are interested or concerned, you should ask your pest control company to show the records of how your building was aerated before it was cleared for re-entry.
- * Call DowElanco Customer Information Service at 1-800-352-6776 if you need additional information or have questions concerning the product.

ANTIQUE TERMITE, INC.

Address: 1913 Stone Avenue, San Jose, CA 95125

Phone: (408) 995-6300

Email: info@antiquetermite.com

Building #, Street, City, State, Zip 3660 Larry Court, San Jose, CA 95121	Date of Inspection 3/9/2021	Report # 63090
---	---------------------------------------	--------------------------

WORK AUTHORIZATION CONTRACT

MARK THE [] CORRESPONDING TO THE ITEM(S) YOU WISH TO AUTHORIZE AND SIGN THE NEXT PAGE
 WE REQUIRE THIS SIGNED CONTRACT AND 1/3 OF THE TOTAL AUTHORIZED AMOUNT BEFORE WORK BEGINS
 PRIMARY FUME/SECONDARY LOCAL RECOMMENDATIONS: CHOOSE ONE OR THE OTHER

Section I			Section II			Further Inspection		
<input type="checkbox"/> 1A	Fumigation	\$2,009.00	<input type="checkbox"/> 1C	Preventative	\$250.00	<input type="checkbox"/> 7A	Attic F/I	BID ON REQ
<input type="checkbox"/> 1B	Mask Pellets	\$225.00				<input type="checkbox"/> 8A	Garage F/I	\$150.00
<input type="checkbox"/> 8C	Fumigation	INCL. W/ 1A				<input type="checkbox"/> 8B	Subarea F/I	BID ON REQ
<input type="checkbox"/> 8D	Mask Pellets	\$200.00						
<input type="checkbox"/> 11A	Wood Repair	\$785.00						
<input type="checkbox"/> Prepay	Prepay Fumig. Discount	-\$150.00						
TOTAL COST AUTHORIZED:			TOTAL COST AUTHORIZED:			TOTAL COST AUTHORIZED:		
\$			\$			\$		

The following items are listed on our report, but referred to other trades:	3A, 11B, 11C, 11D
---	-------------------

ANTIQUE TERMITE, INC.

Address: 1913 Stone Avenue, San Jose, CA 95125

Phone: (408) 995-6300

Email: info@antiquetermite.com

Building #, Street, City, State, Zip 3660 Larry Court, San Jose, CA 95121	Date of Inspection 3/9/2021	Report # 63090
---	---------------------------------------	--------------------------

ANTIQUE TERMITE INC. AGREES: 1: To guarantee all repairs completed by this company for one year from date of notice of completion, except for plumbing, grouting, caulking, and re-setting of toilets, which will be guaranteed for (30) days. We assume no responsibility for work performed by others. 2: To be bound to perform this work for the price quoted in our cost breakdown for a period not to exceed (30) days. 3: To use reasonable care in the performance of our work but to assume no responsibility for damage to any hidden pipes, wiring, or other facilities or to any shrubs, plants, or other life.

OWNER OR OWNER'S AGENT AGREES: 1: To pay for services rendered upon notice of completion of work. Properties which are in escrow are to be paid at the close of escrow, not to exceed 60 days from date of notice of completion. **Properties not in escrow or those with no buyer for same are to be paid within 10 days of notice of completion.** 2: To pay for service charges 1.5% per month or portion of any month beyond the (30) days after completion of work by our company. 3: Owner grants to Antique Termite, Inc. a security interest in the above described real property to secure payment of the sum for work completed and inspection fee. 4: In case of non payment by owner/responsible party, reasonable attorney fees & any costs of collection to be paid by owner/responsible party whether suit is filed or not. 5: **Credit card payments: We accept Visa & Mastercard. ANY CREDIT CARD PAYMENTS OVER \$1000 WILL INCUR A 3% PROCESSING SURCHARGE.**

BOTH PARTIES AGREE: 1: If additional damage is discovered by Antique Termite Inc. in the performance of the work, Antique Termite agrees to notify owner or agent of the amount of the damage and the amount of the additional work necessary to be performed at an additional cost as per supplemental report. Should local building department require additional work to be performed, additional work would be performed at owner's expense. Same would be outlined in a supplemental report. 2: The above additional work to be performed will not be done without written authorization from owner or owner's agent.

NOTICE TO PROPERTY OWNERS: (Under California Contractors License Law) Provides under the Mechanic's Lien Law any contractor, subcontractor, laborer, supplier or other person who helps to improve your property but is not paid for his work or supplies has a right to enforce a claim against your property. This means that, after a court hearing your property could be sold by the court officer and the proceeds of the sale used to satisfy the indebtedness. This can happen even if you paid your own contractor in full, if the subcontractor, laborer or supplier remains unpaid. To preserve their right to file a claim or lien against your property, certain claimants such as subcontractors or material suppliers are required to provide you with a document entitled " Preliminary Notice". Its purpose is to notify you of persons who may have the right to file a lien against your property if they are not paid.

NOTICE OF COMPLETION: document is not to be used until all funds due to ANTIQUE TERMITE, INC as outlined above are in escrow and supplied with full authorization for release by all concerned parties. If there is not the total amount and/or there is not authorization for full release by both parties, completion/certification is to be returned to ANTIQUE TERMITE, INC immediately. To use this completion/certification if the above stipulations are not met is to assume direct legal responsibility for the entire amount due to ANTIQUE TERMITE INC.

CHEMICAL SENSITIVITY OR ALLERGIES: (Note to occupant) Does any person to your knowledge living or working at this address have any chemical sensitivities or allergies that Antique Termite should be aware of prior to work? If yes, they should contact their physician concerning occupancy during and after any chemical treatment, if specified herein, prior to signing below.

MOLD DISCLAIMER: There may be health related issues associated with the structural repairs reflected in the inspection report referenced by this Work Authorization Contract. These health issues include but are not limited to the possible release of mold spores during the course of repairs. We are not qualified to and do not render any opinion concerning such health issues or any special precautions. Any questions concerning health issues or any special precautions to be taken prior to or during the course of such repairs should be directed to a Certified Industrial Hygienist before any such repairs are undertaken.

TIME & MATERIAL: For items which are bid at time and material--cost is based on \$105.00 per man per hour + cost of materials + 10% unless otherwise stated in report.

FUMIGATION PREPAY: If the "Prepay Fumig. Discount" is authorized above, the undersigned agrees to pay the fumigation price indicated above minus the discount indicated above at least two business days prior to their chosen date of fumigation. If the fumigation is NOT prepaid, the undersigned is still responsible for paying 1/3 of the FULL fumigation price at least two business days prior to their chosen date of fumigation.

<p>I have read and understand this work authorization contract, the WDO inspection report it refers to, and the terms outlined above. By signing, I hereby authorize the items/costs indicated on the previous page to be performed pursuant to the terms outlined above.</p>		
<p>X _____ Approved & Read By Antique Termite</p>	<p>_____ Current Date</p>	<p>_____ Preferred Date for Work to Commence</p>
<p>X _____ Approved & Read By</p>	<p>_____ Current Date</p>	<p>_____ Phone #, Email Address, and/or Combo Code</p>